

THIS DOCUMENT CONTAINS PROPRIETARY AND CONFIDENTIAL DATA OF EUROVAC INC. NO DISCLOSURE REPRODUCTION, OR USE OF ANY PART THEREOF, MAY BE MADE WITHOUT WRITTEN PERMISSION OF THE COMPANY.

EUROVAC

116 BUTTERMILL AVE., CONCORD, ONTARIO, L4K 3X7

TEL.: 1-800-265-3878

FAX: 905-738-4603

www.eurovac.com

PRODUCT SPECIFICATIONS

PRODUCT: TYPICAL HIGH VOLUME HOSE DROP WITH BALANCER

FOR APPROVAL

FOR CERTIFICATION

PROJECT: -

PROJECT NO.: -

ORDER NO.: -

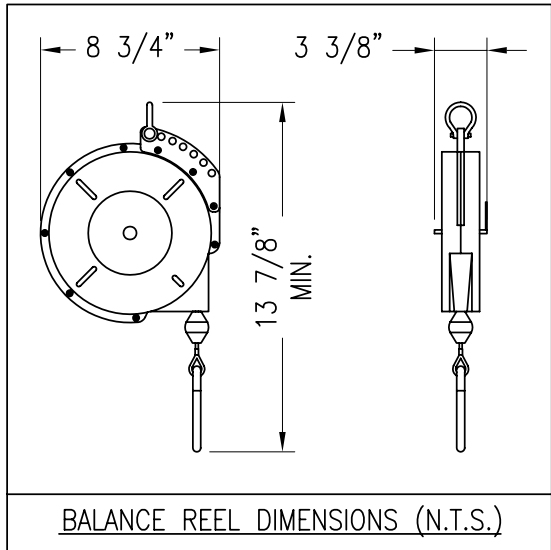
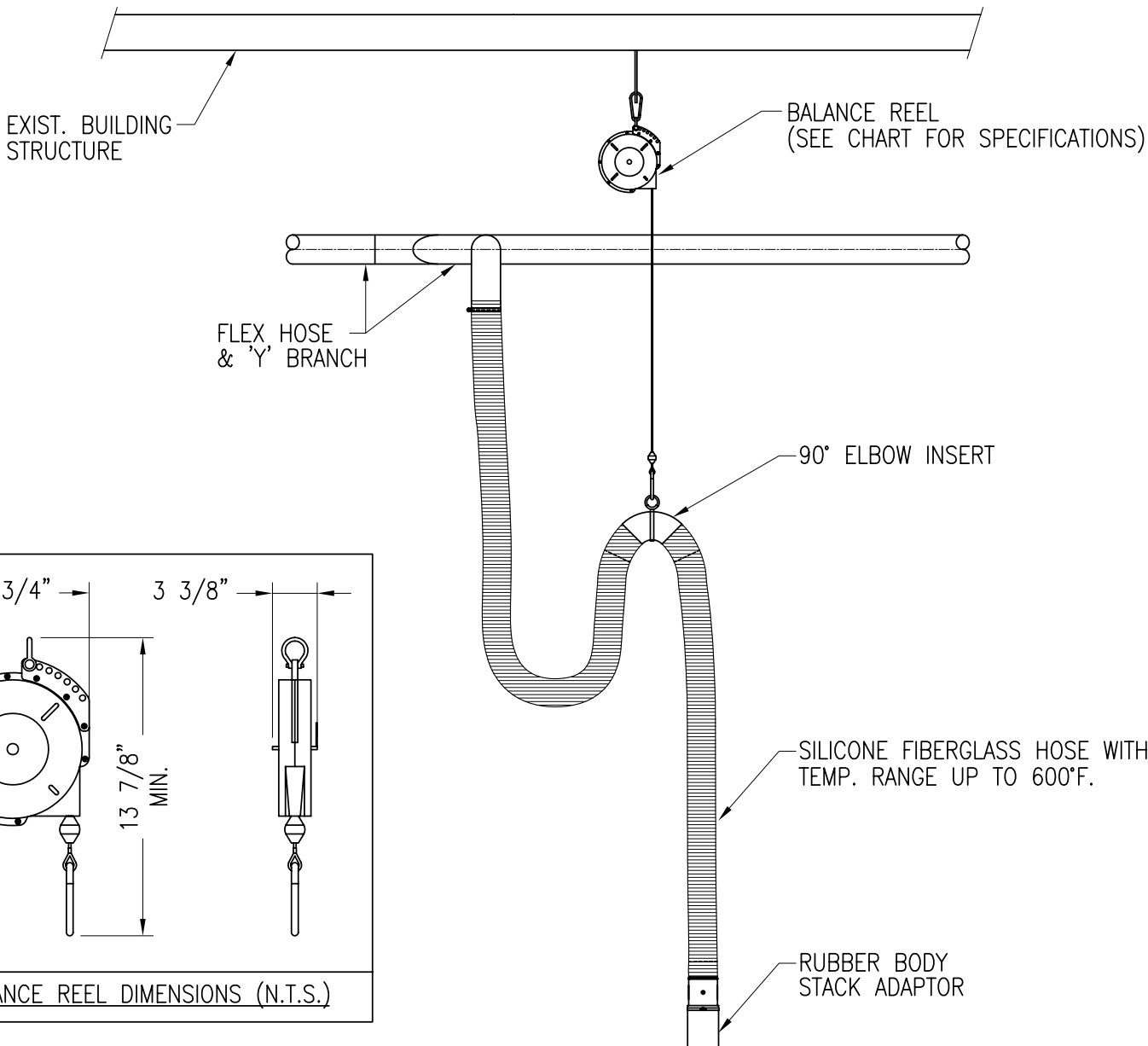

BALANCE REEL SELECTION CHART				
MIN.-MAX. LOAD (lbs.)	CABLE LENGTH (ft.)	REEL WEIGHT (lbs.)	MODEL NUMBER	TYPICAL HOSE SIZE
10 - 15	8	8	SYS-VEH-BR101508	Ø4"
16 - 23	8	8	SYS-VEH-BR162308	Ø6"
22 - 27	8	8	SYS-VEH-BR222708	Ø8"

* ALL BALANCERS COME WITH RATCHET LOCK, UNLESS SPECIFIED OTHERWISE.
 ** 5ft. & 10ft. EXTENSION CABLES ARE AVAILABLE FOR ALL BALANCERS.

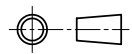

*NOTE: ALL DIMENSIONS ARE IN INCHES.

DIMENSIONS AND DESIGN ARE SUBJECT TO CHANGE TO MANUFACTURER'S DISCRETION.